

2 - Hood/Tank

CODE	DESCRIPTION
120348	MAGN.SWITCH (N.O.)
160811	WASHER F2 18X8.5X1 ALGOF
160907	CONNECTION FOR TABLES C95-155
180642	GUIDE
190637	GUIDE FOR DOOR "C"
190638	ROLLER FOR "C" DOOR GUIDE
190806	MAGNET HOUSING
200925	GASKET
200957	GASKET
200964	GASKET 618X14 SP.2
260104	STAINL.ST TE-SCREW A2 6X16 UNI
260113	STAINL.ST.TE SCREW 8X20 A2 UNI
260202	SCREW TCP 3X16
260219	STAINL.ST TCP SCREW 6X35 A2 UN
260224	TB-SCREW 6X15 B23-10-11-12
260329	VITE M5X12 SPEC.ZIGR.SOTTOTEST
260404	STAINLESS STEEL NUTS D6 UNI 55
260418	SELF-LOCKING NUT M4
260502	S/S FLAT WASHER D.4
260504	ST/ST FLAT WASHER D6
260505	STAINL.STEEL FLAT WASHER D8
260512	ST/ST GROWER WASHER D6
260513	GROWER WASHER D8
260530	STAINL.ST WASHER 7X22X2
260538	WASHER 18X6X1,5 ST/ST
260543	WASHER D.6 ST/ST
320534	LOWER FRAME
324016	SWITCH BRACKET
332424	SQUADRETTA SOST.TUBO PRESS.C
342258	TANK
342497	HOOD
342498	INSULATED HOOD
351421	LEFT PANEL
351422	RIGHT PANEL
351767	FRONT PANEL
351870	FRONT PANEL LC2004
361076	FRAME
390182	BACK PANEL
411002	PERMANENT MAGNET 24X12
440211	LEGS
530238	RACK SUPPORT C-SERIES

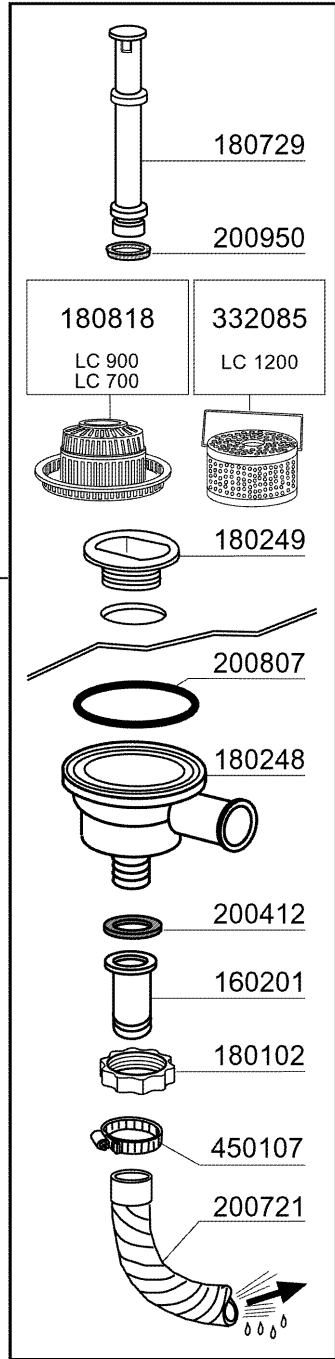
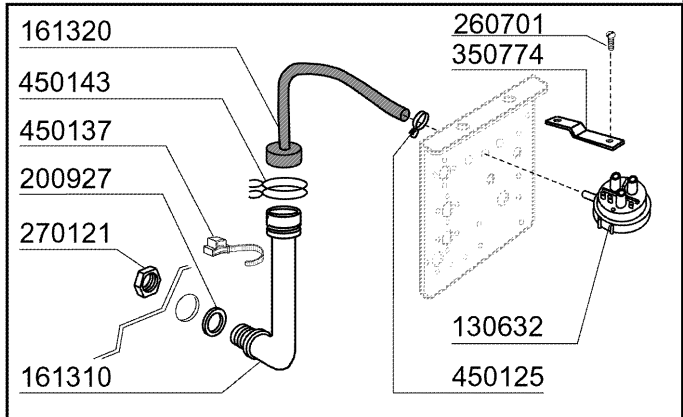
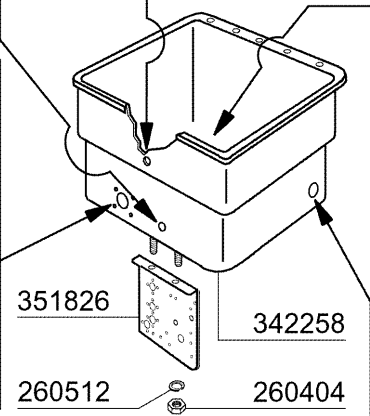
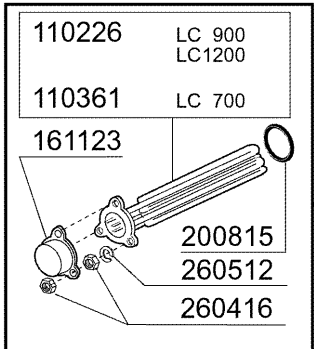
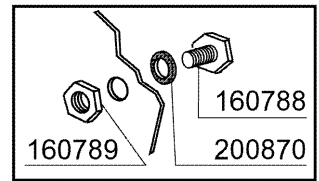
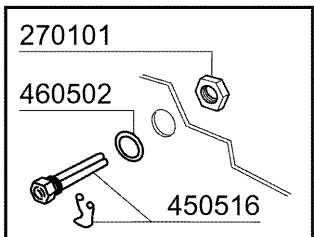
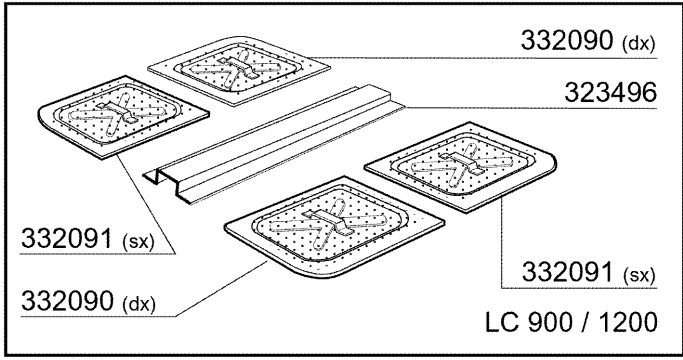

05 - 2005 | S. AG.

3 - Tank

CODE	DESCRIPTION
110226	HEAT. ELEMENT 3000W 230/400V
110361	HEAT. ELEMENT 2200W 230V
130632	PRESSURE SWITCH 1L
160201	ELBOW F.TANK INLET MOPLN
160788	PLUG
160789	NUT
161123	HEAT.ELEMENT COVER H42 SNL
161310	AIR CHAMBER FOR GLASSWASHERS B
161320	HOSE FOR AIR CHAMBER
180102	DRAIN PIPE NUT 1"1/2 F45-55
180248	SUCTION TANK
180249	NUT
180729	OVERFLOW PIPE
180818	STRAINER FOR FC
200412	GASKET DRAIN 11/2" 45X33X3
200721	DRAIN HOSE 28X35 2MT.
200807	O-RING 3,53 X 110,72
200815	O-RING F. HEAT.ELEM.
200870	GASKET 18X10X2
200927	GASKET FOR AIR TRAP
200950	VITON GASKET
260404	STAINLESS STEEL NUTS D6 UNI 55
260416	STAINLESS STEEL NUTS M6
260512	ST/ST GROWER WASHER D6
260701	SCREW 3,5X9,5
270101	HEXAGON LOCK NUT 1/2"
270121	NUT FOR AIR TRAP
323496	STRAINERS SUPPORT
332085	STRAINER LC
332090	RIGHT STRAINER
332091	TANK LEFT STRAINER
342258	TANK
350774	BRACKET
351826	BRACKET
450107	CLAMP FE ZN 38-50 H=12,2
450125	ELASTIC CLAMP D. 10,4X9,8
450137	COLLAR CONNECTION WITH BASE 31
450143	CLAMP D.39,7 X 37,7
450516	THERMOSTAT SHIELD FOR 2 TERMOS
460502	GASKET 30X21X2

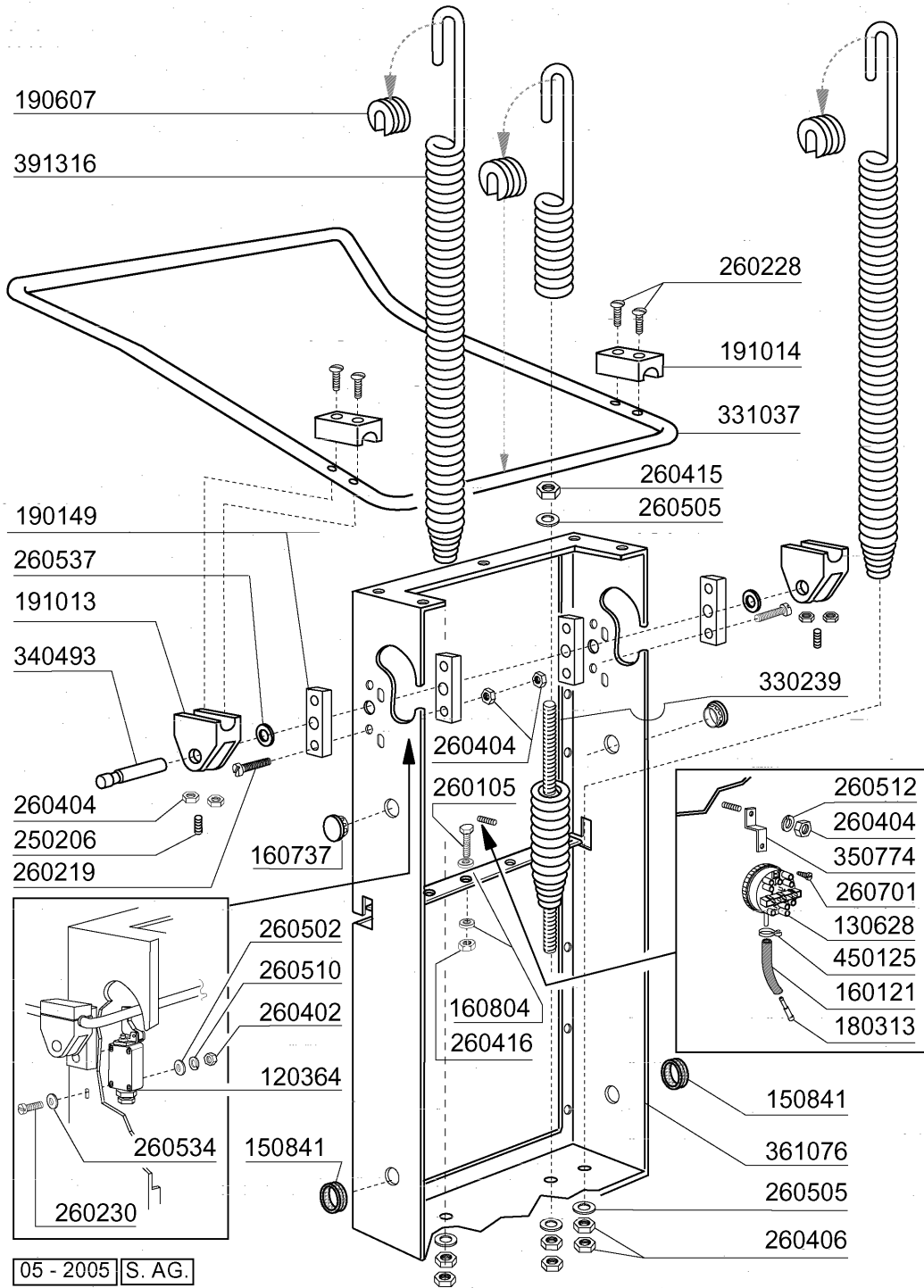

4 - Handle

CODE	DESCRIPTION
120364	LIMIT SWITCH WITH LEVER
130628	PRESSURE SWITCH
150841	CABLE HOLDER
160121	HOSE EPDM D. 5 X 9
160737	PLUG HEYCO D.34,9
160804	GASKET D.6
180313	TEE-NIPPLE
190149	REINFORCEMENT FOR HANDLE SUPP.
190607	HANDLE BUSH C30-70
191013	HINGE F. SUPPORT C30-C70
191014	FLANGE F. HANDLE C30-70
250206	GRUB SCREW D.6
260105	SCREW TE 6X20
260219	STAINL.ST TCP SCREW 6X35 A2 UN
260228	STAINL.ST SPECIAL SCREW 6X42 3
260230	SCREW TCP 4X40
260402	STAINLESS STEEL NUT D4 UNI 55
260404	STAINLESS STEEL NUTS D6 UNI 55
260406	NUT 8MA
260415	STAINLESS STEEL SELF-LOCKING N
260416	STAINLESS STEEL NUTS M6
260502	S/S FLAT WASHER D.4
260505	STAINL.STEEL FLAT WASHER D8
260510	GROWER WASHER D.4
260512	ST/ST GROWER WASHER D6
260534	WASHER
260537	STAINL.STEEL FLAT WASHER D13X2
260701	SCREW 3,5X9,5
330239	ROD
331037	HANDLE C95-155-165 ISOLATED
340493	PIN F. HINGE C30
350774	BRACKET
361076	FRAME
391316	SPRING FOR HANDLE C85/140-G75
450125	ELASTIC CLAMP D. 10,4X9,8

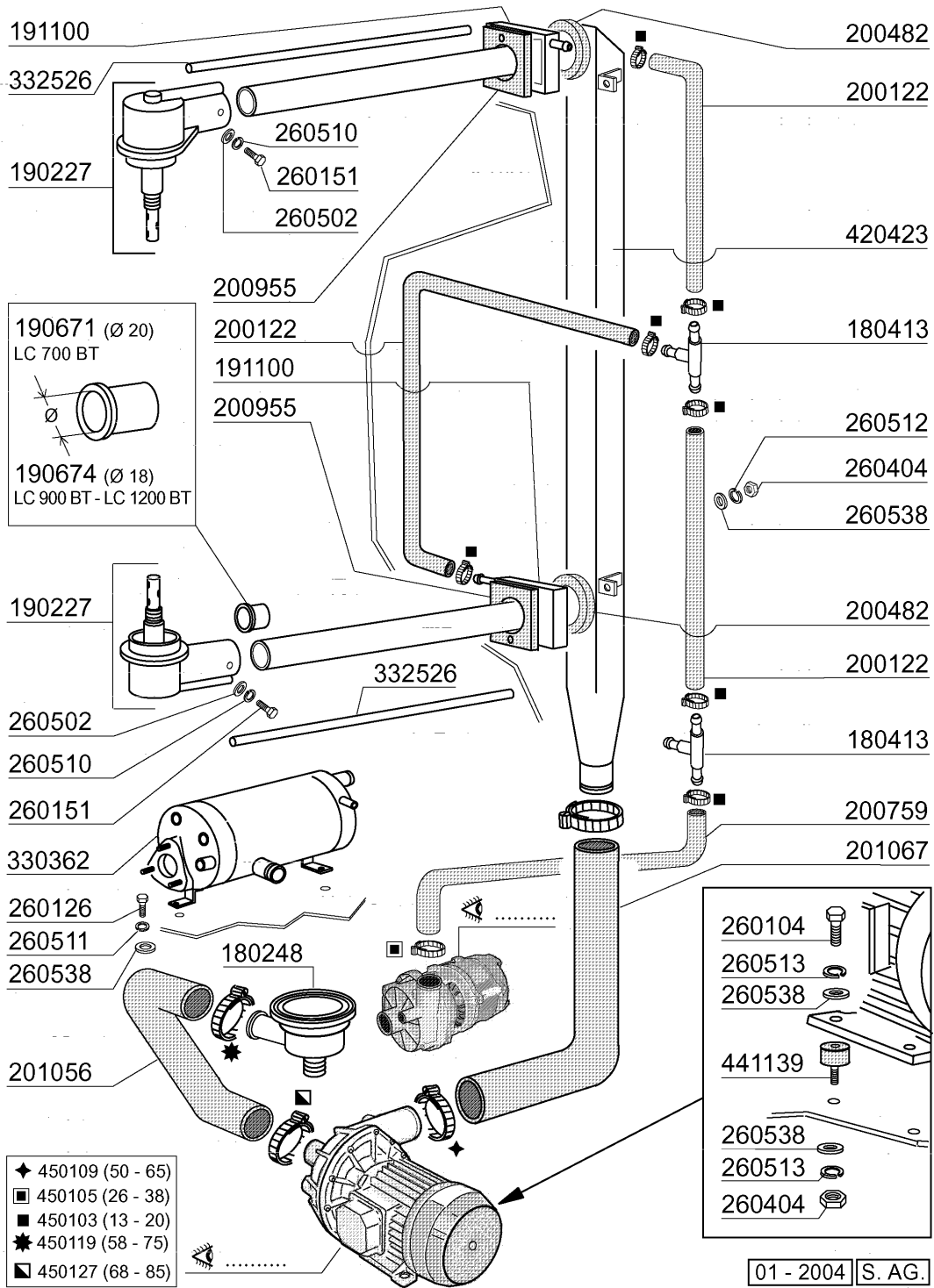

01 - 2004 | S. AG.

5 - Wash/Rinse column

CODE	DESCRIPTION
180248	SUCTION TANK
180413	TEE NIPPLE D.11,5 - RINSE ASSE
190227	ARM SUPPORT
190671	BUSH
190674	BUSH
191100	RINSE COLLECTOR C-LC
200122	HOSE 11X19
200482	GASKET 60X54 RAMP C140
200759	DELIVERY HOSE FOR ECORINSE AC-
200955	GASKET
201056	WASH PUMP INLET HOSE
201067	OUTLET HOSE
260104	STAINL.ST TE-SCREW A2 6X16 UNI
260126	SCREW TE 5X12
260151	SCREW TE 4X12
260404	STAINLESS STEEL NUTS D6 UNI 55
260502	S/S FLAT WASHER D.4
260510	GROWER WASHER D.4
260511	GROWER WASHER D.5
260512	ST/ST GROWER WASHER D6
260513	GROWER WASHER D8
260538	WASHER 18X6X1,5 ST/ST
330362	BOOSTER FOR BREAK TANK
332526	RINSE HOSE
420423	WASH RAMP C/LC
441139	VIBRATION-DAMPING FEET 25X20X6
450103	CLAMP FE ZN. 13-20 H=9
450105	CLAMP FE ZN. 26-38 H=12,2
450109	CLAMP 50-65
450119	CLAMP FE ZN. 58-75 H=12,2
450127	CLAMP FE ZN. 68-85 H=12,2

* dalla matricola
a partir de la matr.
from serial no.
ab Seriennr.
despues la matr.
01 - 2003

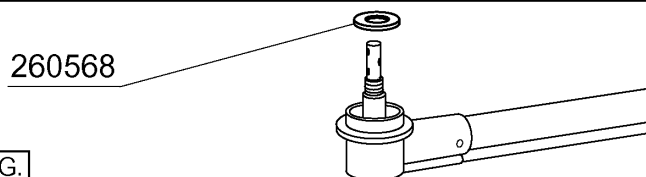
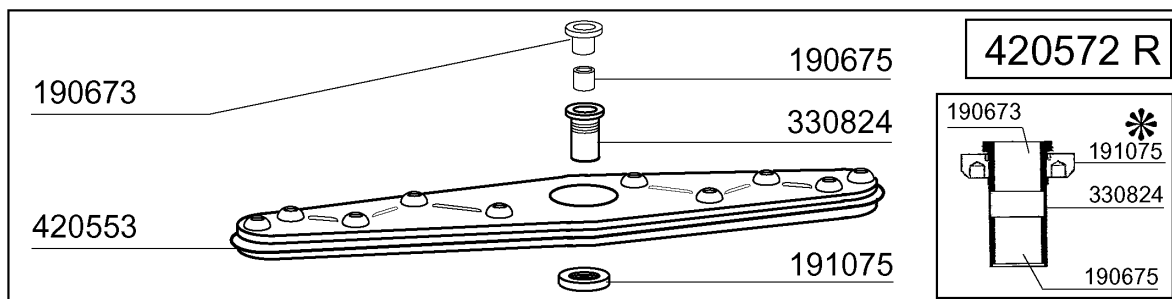
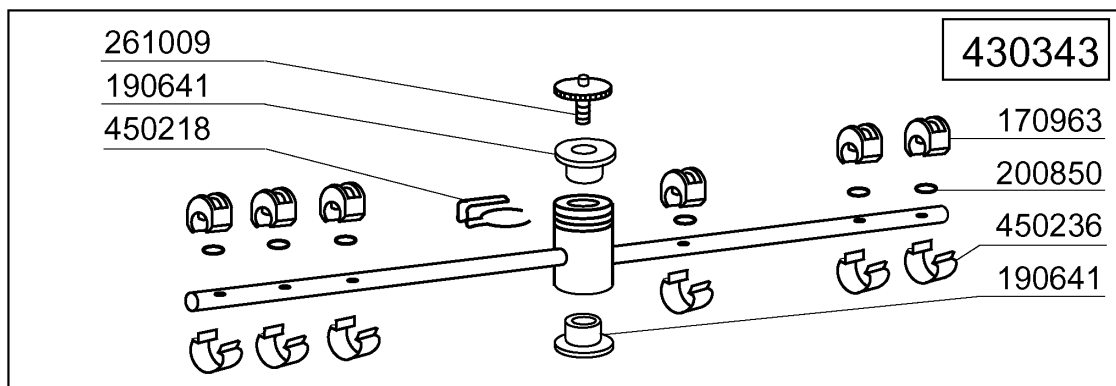
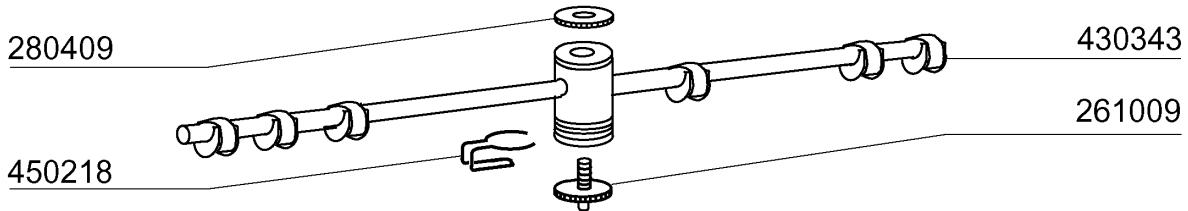
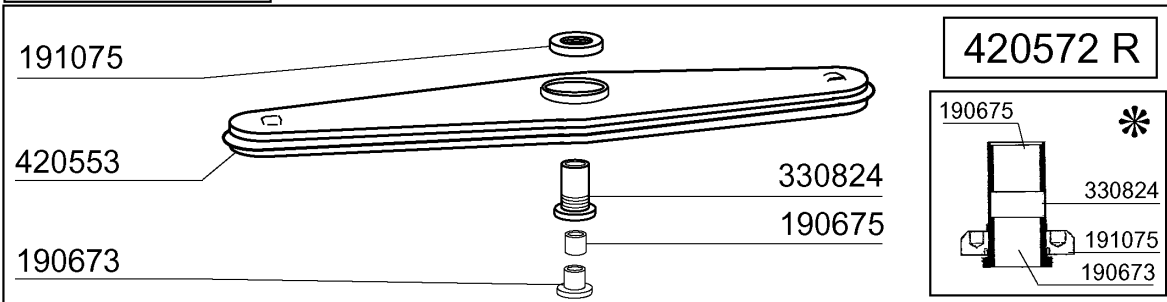
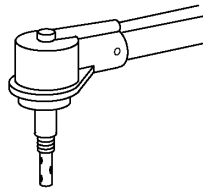

07 - 2003 S.A.G.

6 - Wash arm

CODE	DESCRIPTION
170963	RINSE JET X FC
190641	BUSH FOR C95-155-165 RINSE ARM
190673	BUSH
190675	BUSH
191075	RETAIN.LOCK
200850	O-RING
260568	S/S FLAT WASHER D.28X21X1
261009	RETAIN.SCREW FOR WASH-RINSE AR
280409	RETAIN.LOCK NUT CENTR.CROSS C1
330824	WASH ARM CENTER (STAINL.)
420553	S/STEEL WASH ARM - 420572R
420572R	WASH ARM LC
430343	RINSE ARM LC700/900/1200
450218	SPRING F.RINSE ARM RETAIN.SCRE
450236	SPRING FOR WASHER 170963

7 - Rinse assembly/Break tank

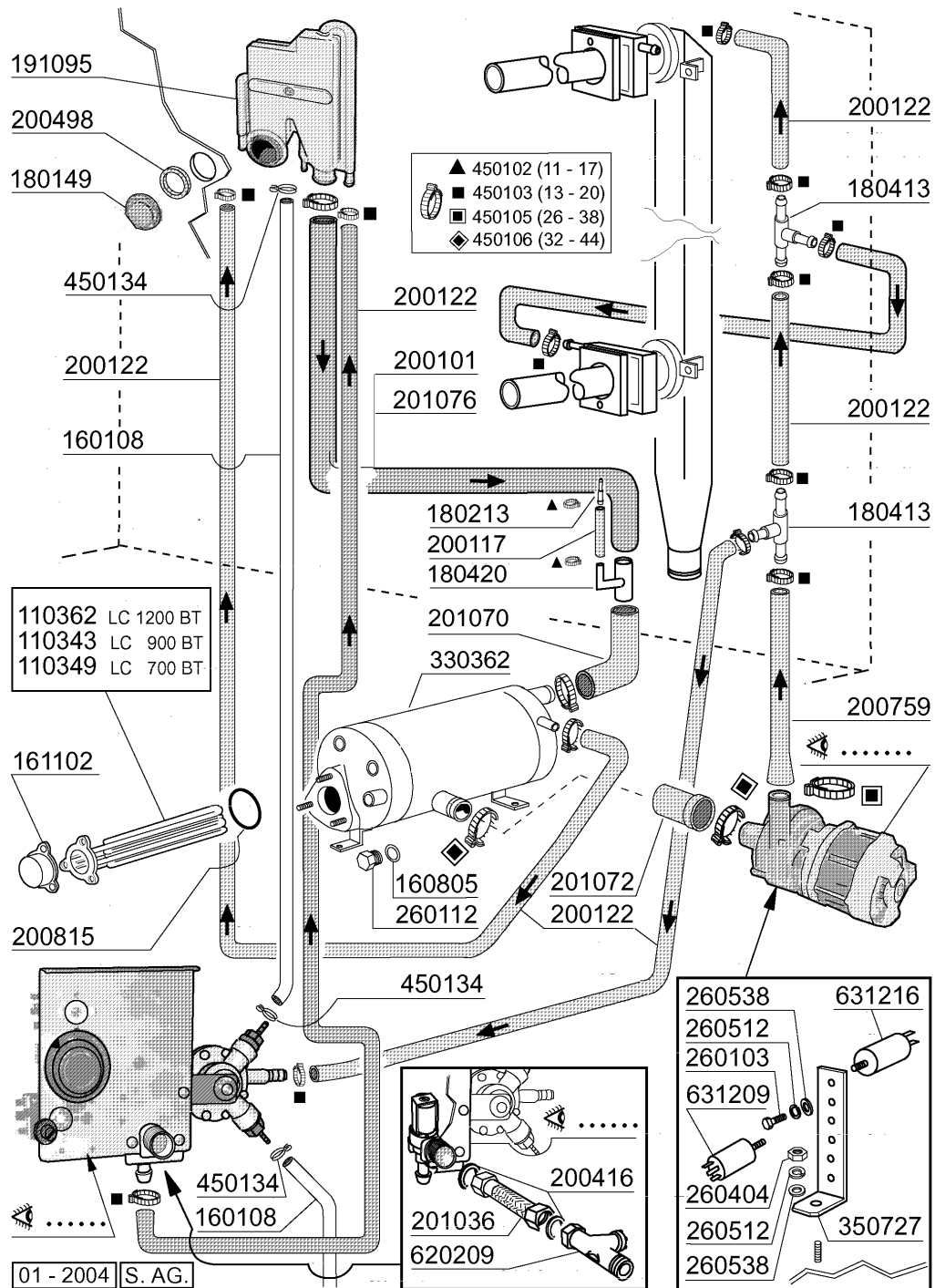

7 - Rinse assembly/Break tank

CODE	DESCRIPTION
110343	HEAT.ELEM. 8000W 220/380V
110349	HEAT.ELEMENT 6000W 230/400V
110362	HEAT.ELEMENT 9000W 220/380V
160108	INJECT.INLET HOSE D.8X5
160805	GASKET D.8
161102	ELEMENT COVER MOPL.
180149	PLASTIC NUT
180213	FLANGE F.JET LOCKING F2-C34
180413	TEE NIPPLE D.11,5 - RINSE ASSE
180420	TEE-NIPPLE
191095	CONTAINER FOR BREAK TANK
200101	RUBBER TUBE 25X35
200117	RUBBER HOSE 7X16
200122	HOSE 11X19
200416	GASKET D. 3/4"
200498	GASKET
200759	DELIVERY HOSE FOR ECORINSE AC-
200815	O-RING F. HEAT.ELEM.
201036	INLET HOSE 2 MT
201070	HOSE
201072	HOSE
201076	HOSE
260103	SCREW TE 6X12
260112	STAINLESS STEEL TE-SCREW 8X16
260404	STAINLESS STEEL NUTS D6 UNI 55
260512	ST/ST GROWER WASHER D6
260538	WASHER 18X6X1,5 ST/ST
330362	BOOSTER FOR BREAK TANK
350727	BRACKET
450102	CLAMP FE ZN 11-17 H=9
450103	CLAMP FE ZN. 13-20 H=9
450105	CLAMP FE ZN. 26-38 H=12,2
450106	CLAMP FE ZN 32-44 H=12,2
450134	ELASTIC HOSE CLIP D.9,3/8,8
620209	INLET WATER FILTER
631209	ANTI-NOISE FILTER
631216	CAPACITOR 6.3 MF 450V

630330
630252
630411
630501

632501 50 HZ
632502 60 HZ
630138

631202
16 μ F

630254

LC 700 BT
100801
220/240 V
50 Hz - HP 1
Kw 0,75 (5223)

630306
630252
630411
630501
631653 50 HZ ★
631618 50 HZ ★★

631654 60 HZ ★
631647 60 HZ ★★
630138

630253

LC 900 BT
100797 ★
230/400V
50 Hz - HP 1,5
Kw 1,1 (5233)

LC 1200 BT
100795 ★★
230/400V
50 Hz - HP 2
Kw 1,5 (5234)

630249
630533
631698
630427

630136

631216
6,3 μ F

100802
230V - 50 Hz
Kw 0,2
(ZF131 DX)

01 - 2004 | S. AG.

8 - Pump

CODE	DESCRIPTION
100795	PUMP 2HP 380/3/50HZ
100797	PUMP HP 1,5 380/3/50
100801	PUMP 1HP 230/1
100802	PUMP HP 0,3 230V-50HZ
630136	PUMP VOLUTE LGB ZF131DX
630138	VOLUTE FOR PUMP LC
630249	PUMP FLANGE ZF131 DX
630252	BACK PLATE PUMP LC
630253	FAN HOUSING FOR PUMP 100797
630254	FAN HOUSING FOR PUMP 100801
630306	PUMP FAN IMPELLOR FI HP.2-3
630330	PUMP 100801 FAN IMPELLOR
630411	O-RING PUMP FI HP 2-2,7
630427	O-RING FOR PUMP ZF131DX
630501	SEAL FOR PUMP HP 2-3-3,2
630533	PUMP SEALS WASH PUMP ZF131DX
631202	CONDENSER 16 MF 450V
631216	CAPACITOR 6.3 MF 450V
631618	IMPELLER PUMP F HP2-D.116,5
631647	IMPELLER D.100-60HZ-1204/5
631653	PUMP IMPELLER 1,5 HP 50HZ 1241
631654	PUMP IMPELLER 1,5HP 50HZ 1241
631698	PUMP IMPELLER ZF131DX
632501	PUMP IMPELLER 1HP 50HZ-5223
632502	PUMP IMPELLER 1HP 60HZ-5223

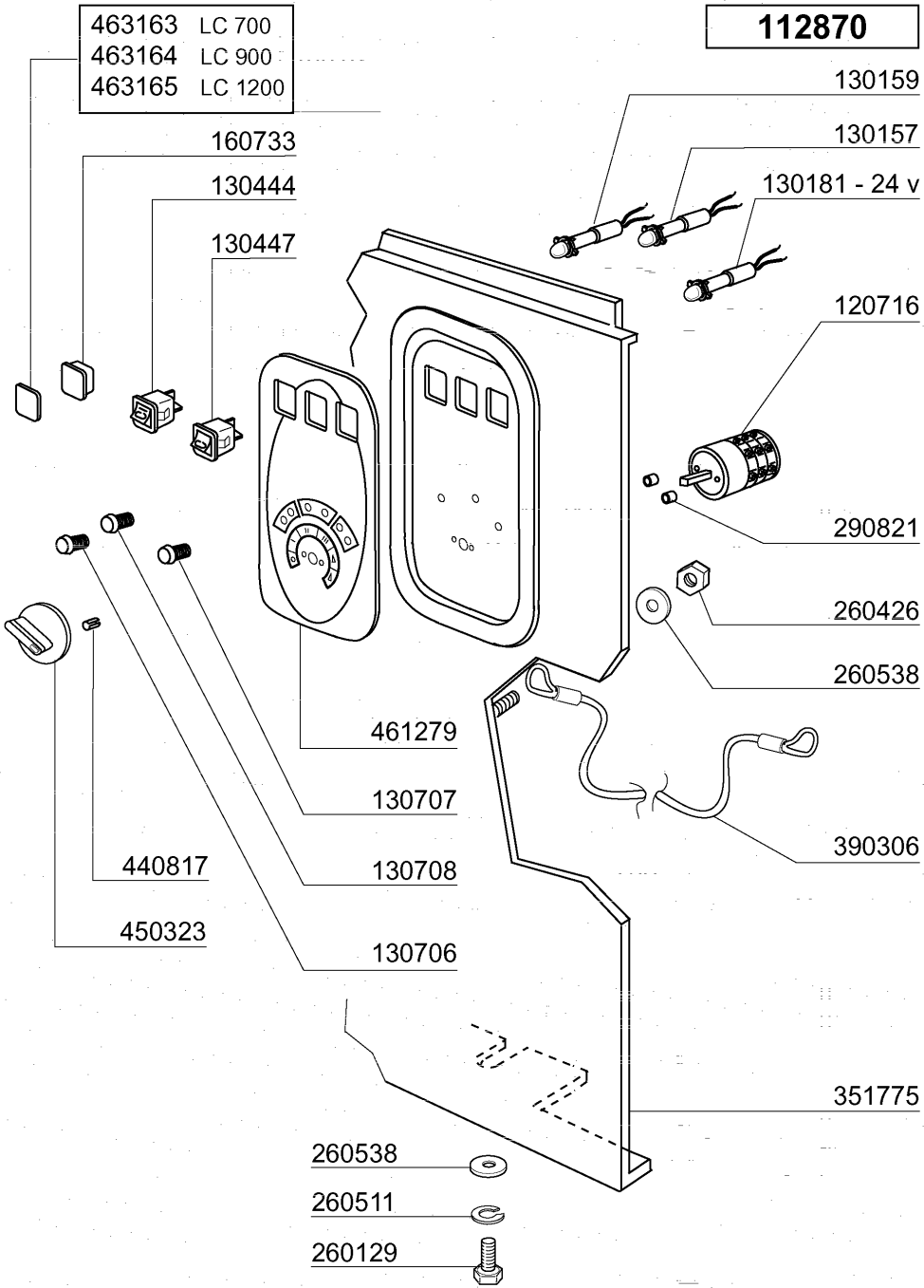

05 - 2004 | S. AG.

9 - Control panel

CODE	DESCRIPTION
112870	CABLE
120716	6 POLES SWITCH 16A
130157	GREEN LED FOR BR-BC-C-SERIES -
130159	ORANGE LED FOR C-SERIES - 220V
130181	GREEN LAMP 24V
130444	SWITCH "START CYCLE" F
130447	CYCLE START SELECTOR FOR C-SER
130706	ORANGE LENS COVERS (C-SERIES)
130707	TRANSPARENT LENS COVERS (C-SER
130708	GREEN LENS COVERS (C-SERIES)
160733	BLANK PLATES
260129	SCREW TE M 5X20
260426	DADI ESAG.CIECHI INOX "M6"
260511	GROWER WASHER D.5
260538	WASHER 18X6X1,5 ST/ST
290821	DISTANCE PIECE FOR SWITCH
351775	FRONT PANEL
390306	CABLE
440817	SNAP RING LSCB/1853/17/00
450323	KNOB FOR BC-BR-C95-C155
461279	PLATE
463163	LC700 PLATE
463164	LC900 PLATE
463165	LC1200 PLATE

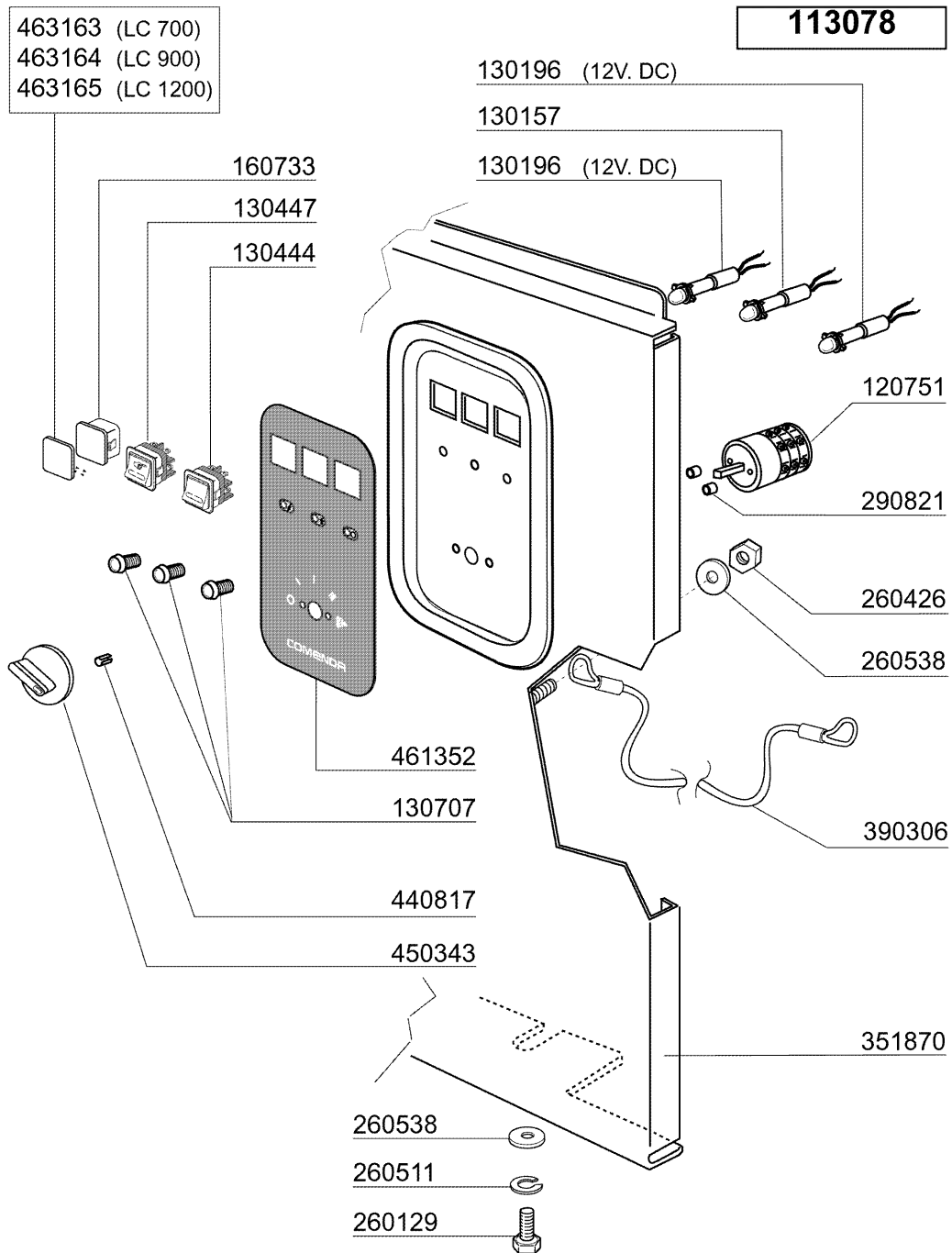

05 2005 | S. AG.

10 - Control panel

CODE	DESCRIPTION
113078	PANN.COM.LC '04
120751	4 POLE SWITCH 16A
130157	GREEN LED FOR BR-BC-C-SERIES -
130196	GREEN LAMP
130444	SWITCH "START CYCLE" F
130447	CYCLE START SELECTOR FOR C-SER
130707	TRANSPARENT LENS COVERS (C-SER
160733	BLANK PLATES
260129	SCREW TE M 5X20
260426	DADI ESAG.CIECHI INOX "M6"
260511	GROWER WASHER D.5
260538	WASHER 18X6X1,5 ST/ST
290821	DISTANCE PIECE FOR SWITCH
351870	FRONT PANEL LC2004
390306	CABLE
440817	SNAP RING LSCB/1853/17/00
450343	BLUE SWITCH
461352	LC2004 PLATE
463163	LC700 PLATE
463164	LC900 PLATE
463165	LC1200 PLATE

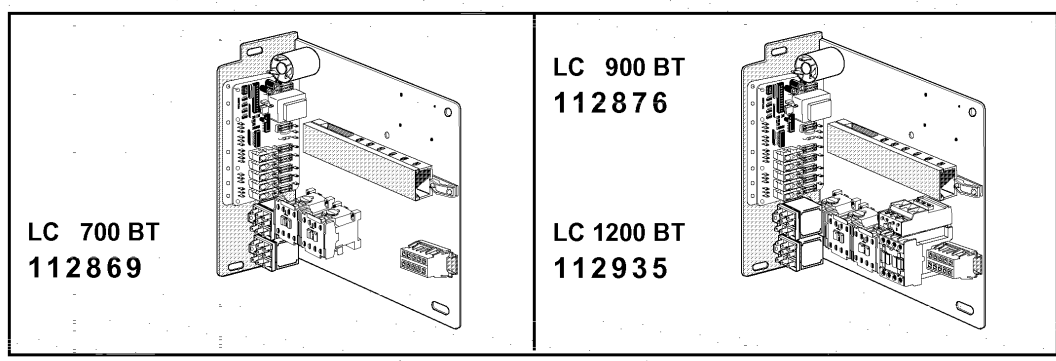
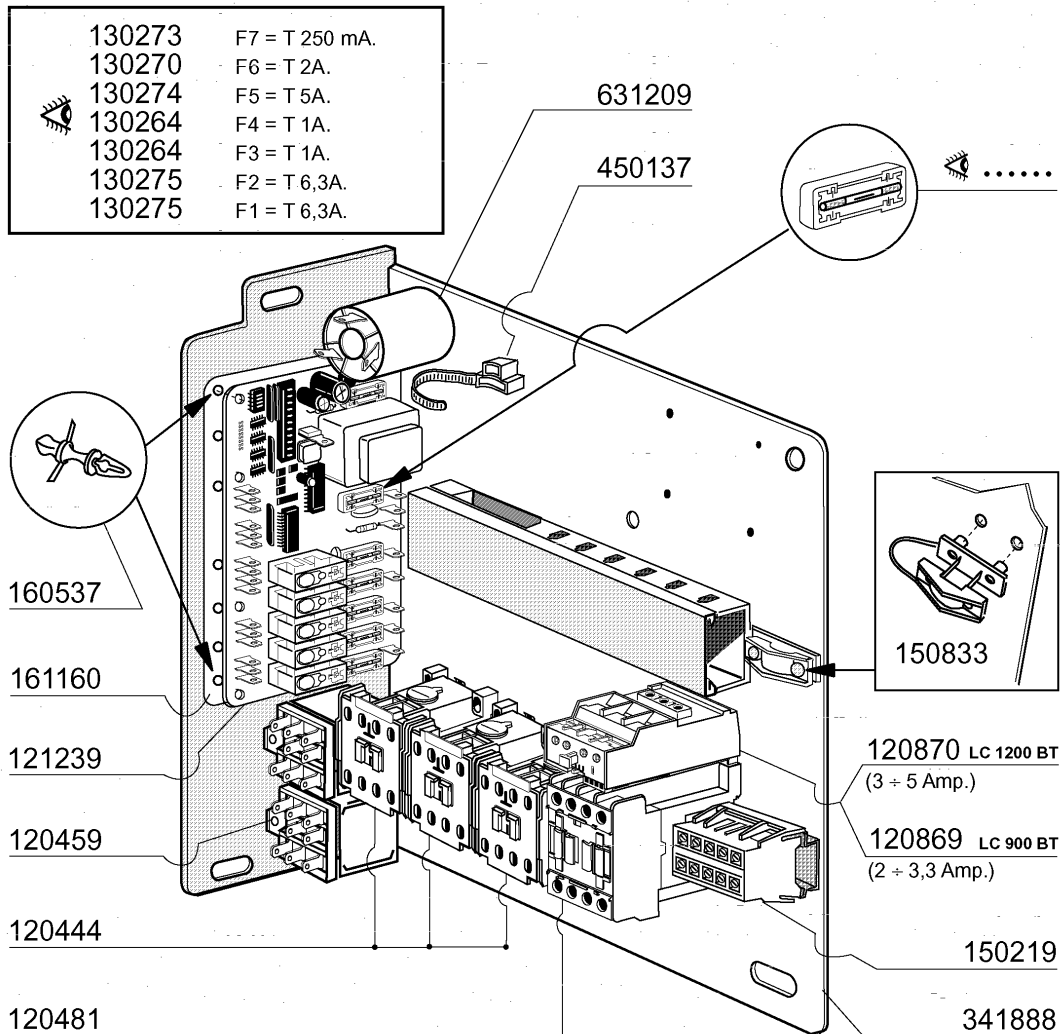

01 - 2004 | S. AG.

11 - Control box

CODE	DESCRIPTION
112869	CABLE
112876	IMP.EL.LC900BT
112935	IMP.EL.LC1200BT
120444	CONTACTOR 9A 220V 50HZ
120459	AUXIL.RELE 16A 220V
120481	CONTACTOR 9A-230V 50/60HZ
120869	OVERLOAD RELAY 2/3,3
120870	OVERLOAD RELAY 3/5
121239	ELECTR.TIMER UNICOM FOR BREAK
130264	FUSE 5X20 1A
130270	FUSE 5X20 2A
130273	FUSE 5X20 250MA GLAS
130274	FUSE 5X20 5A GLAS
130275	FUSE 5X20 6,3A GLAS
150219	TERMINAL BLOCK 5P MMQ165VD26
150833	CABLE HOLDER BC/BR
160537	ELECTRONIC CARD SPACER
161160	PROTECTION ELECT.CARD C/F
341888	CONTROL BOX SUPPORT
450137	COLLAR CONNECTION WITH BASE 31
631209	ANTI-NOISE FILTER

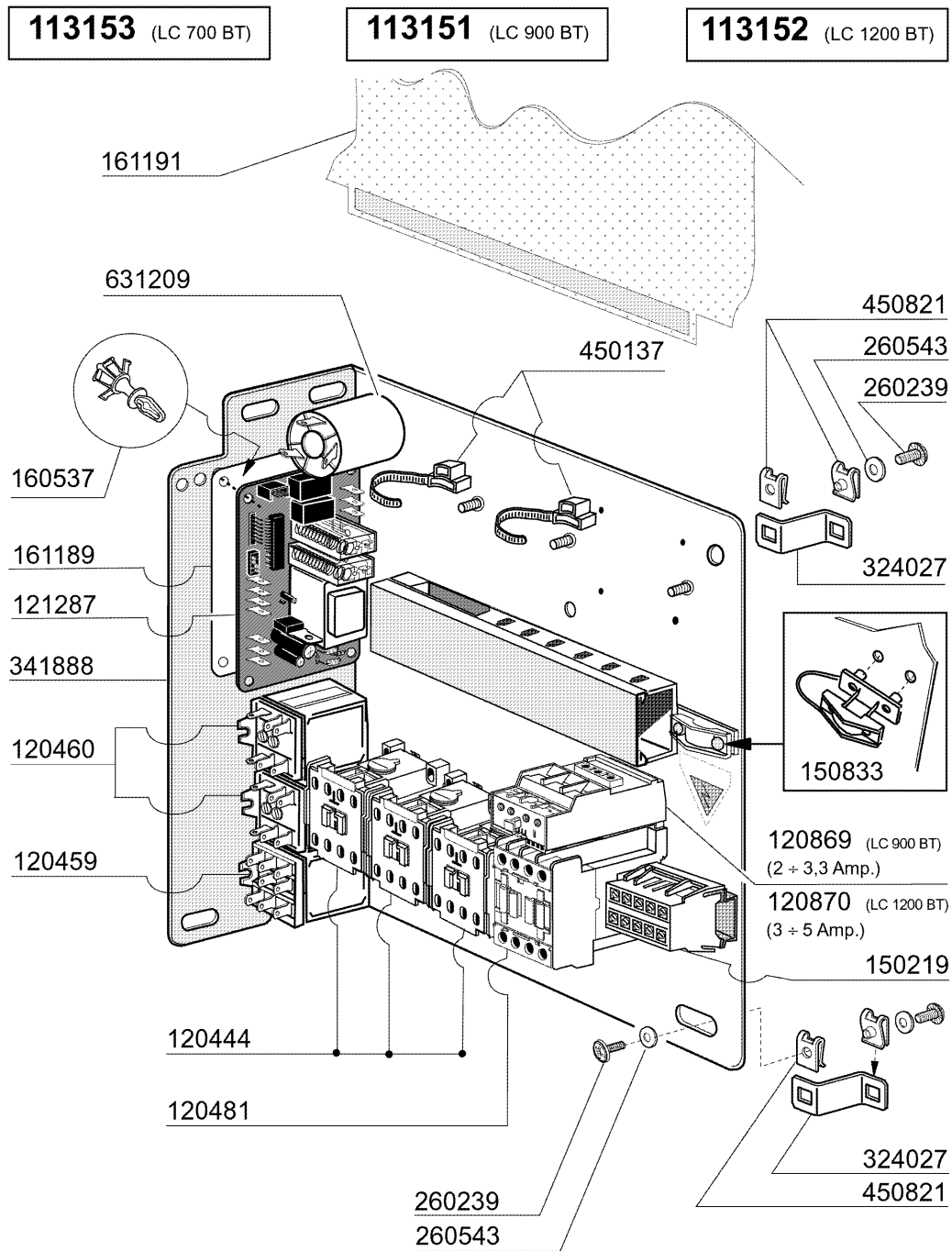

12 - Control box

CODE	DESCRIPTION
113151	WIRING LC900-BT
113152	WIRING LC1200-BT
113153	WIRING LC700-BT
120444	CONTACTOR 9A 220V 50HZ
120459	AUXIL.RELE 16A 220V
120460	RELAY 16A 220V
120481	CONTACTOR 9A-230V 50/60HZ
120869	OVERLOAD RELAY 2/3,3
120870	OVERLOAD RELAY 3/5
121287	ELECTRONIC TIMER
150219	TERMINAL BLOCK 5P MMQ165VD26
150833	CABLE HOLDER BC/BR
160537	ELECTRONIC CARD SPACER
161189	COVER
161191	CONTROL BOX COVER
260239	SPECIAL S/S TB-SCREWS M6X20
260543	WASHER D.6 ST/ST
324027	SQUADR.FISS.IMP.EL. LC 2001-08
341888	CONTROL BOX SUPPORT
450137	COLLAR CONNECTION WITH BASE 31
450821	SPRING CLIP FASTENER SNU 3634
631209	ANTI-NOISE FILTER

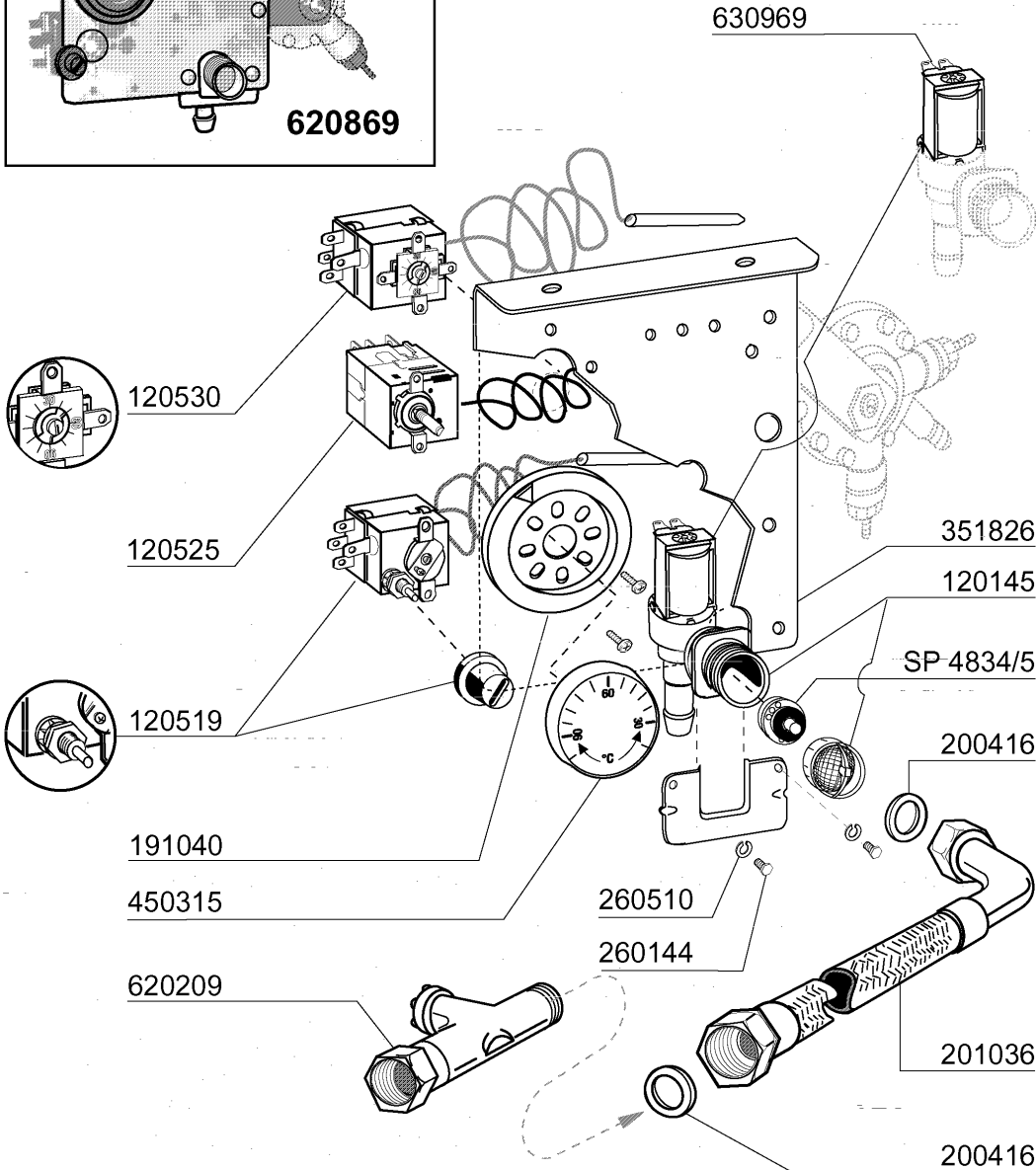
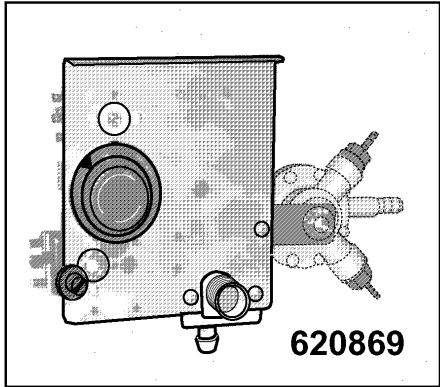

04 - 2004 | S. AG.

13 - Thermostat/solenoid valve group

CODE	DESCRIPTION
120145	SOLENOID VALVE 12 LT 1 WAY
120519	SECURITY THERMOSTAT 95-125Ø
120525	BOOSTER THERMOSTAT 2 TEMPERAT.
120530	THERMOSTAT 0-90Ø
191040	FRAME F.THERMOSTAT KNOB
200416	GASKET D. 3/4"
201036	INLET HOSE 2 MT
260144	SCREW TE 4X6
260510	GROWER WASHER D.4
351826	BRACKET
450315	KNOB F. THERMOSTAT 90Ø
620209	INLET WATER FILTER
620869	ASSIEME COMPONENTI LC-BT
630969	COIL S4216 220/50HZ
SP4834/5	SOLENOID VALVE REGULATOR

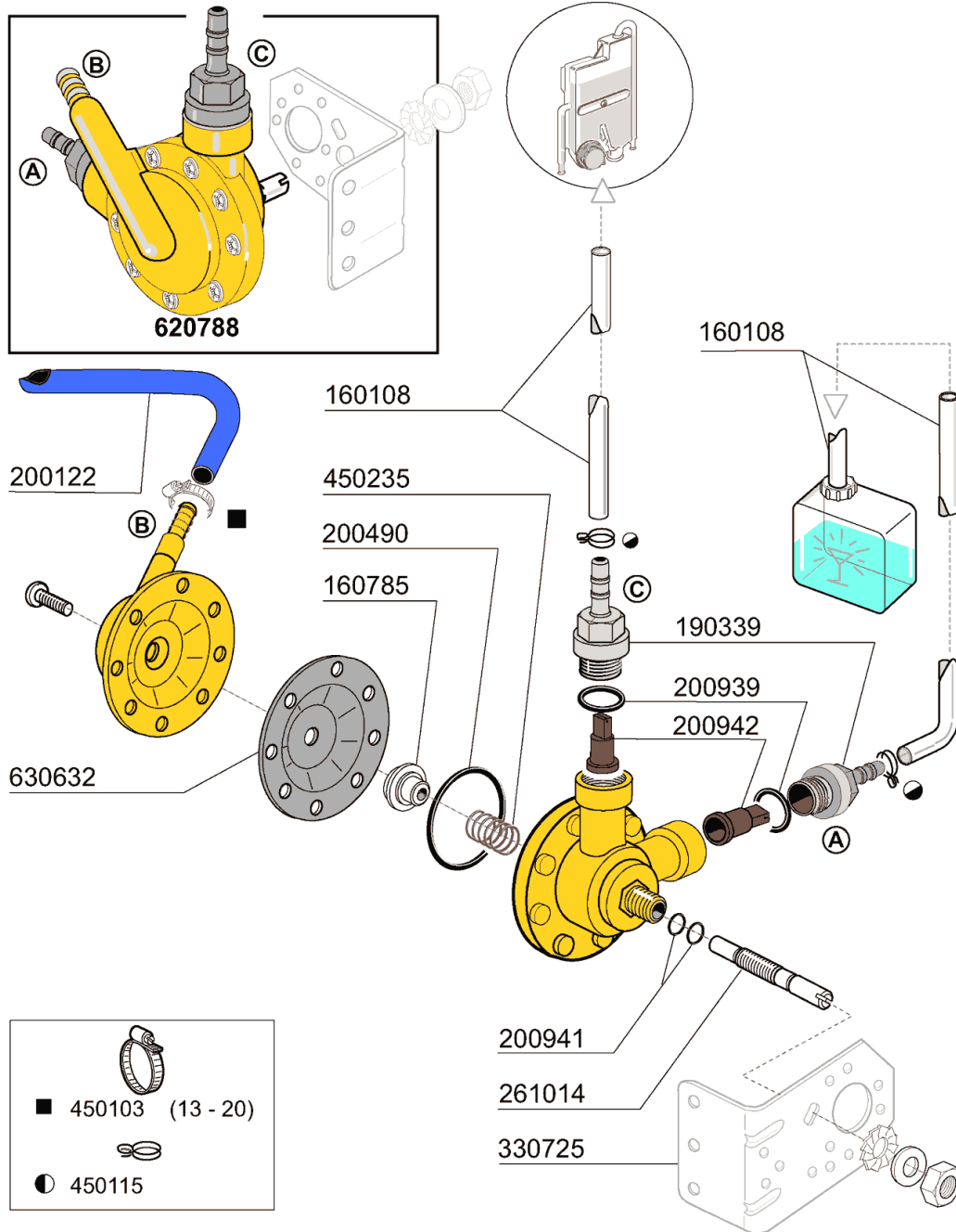

04 - 2007 | S. AG.



14 - Rinse aid injector

CODE	DESCRIPTION
160108	INJECT.INLET HOSE D.8X5
160785	GUIDE FOR SPRING RINSE AID INJ
190339	RINSE AID INJECTOR CONNECTION
200122	HOSE 11X19
200490	PROTECTION GASKET MOD.ADV.
200939	OR GASKET
200941	OR GASKET
200942	VALVE RINSE INJECTOR HVD
261014	SCREW
330725	STANDARD BRACKET F.SOLEN.VALV
450103	CLAMP FE ZN. 13-20 H=9
450115	ELASTIC CLAMP D.8,3/7,8
450235	SPRING RINSE AID INJECTOR
620788	RINSE AID INJECTOR H21428
630632	DIAPHRAGM RINSE INJECTOR HVD

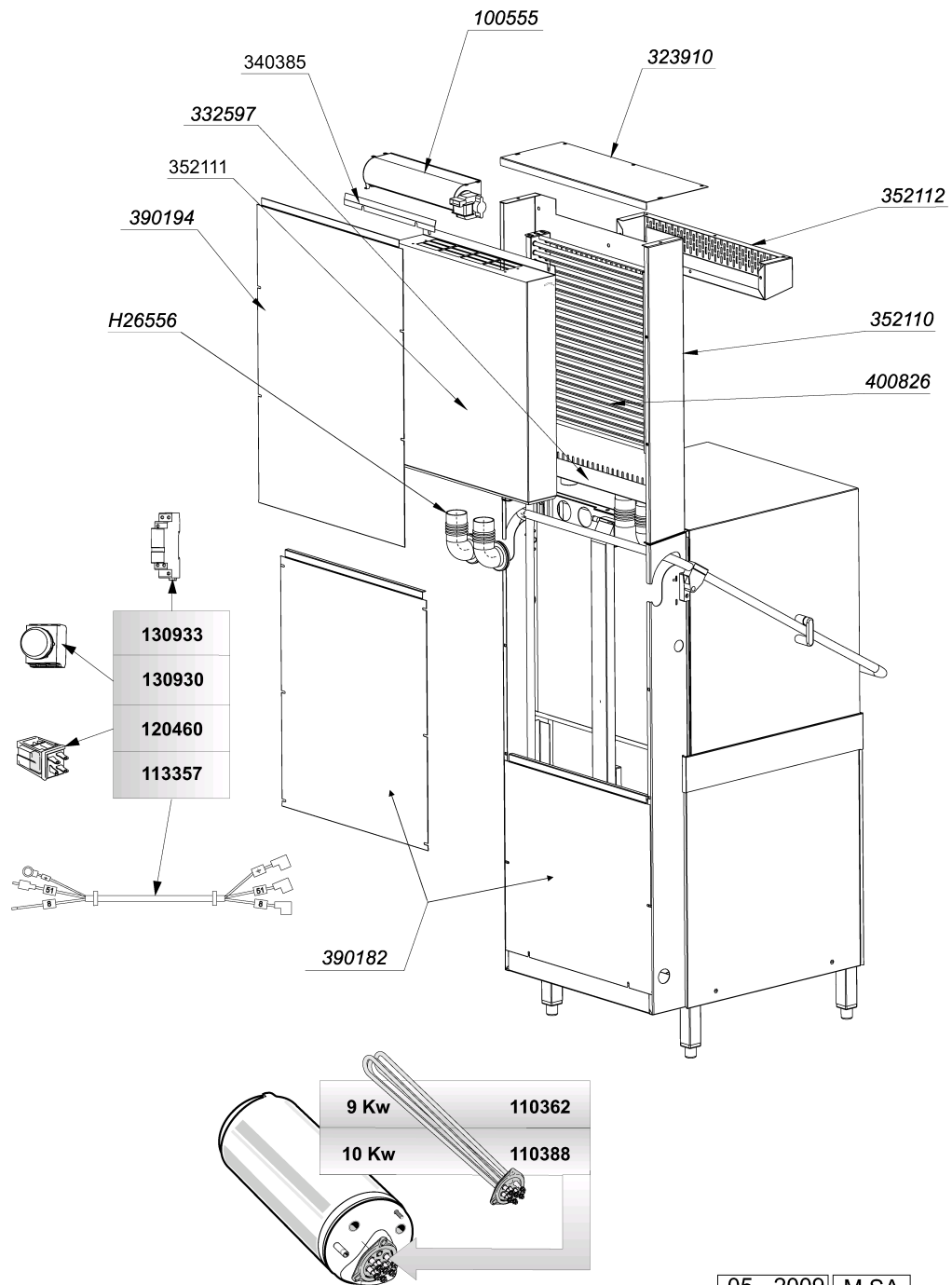

CODE	DESCRIPTION
100555	FAN TGA60/1 360-30
110362	HEAT.ELEMENT 9000W 220/380V
110388	HEAT.ELEMENT 10000W 230/400V
113357	CABLE FOR CRC
120460	RELAY 16A 220V
130930	CONTACT ABB 1NO/1NC 180"
130933	SUPPL. CONTACT NO/NC ABB
323910	CRC UPPER COVER
332597	COLLETTORE ASPIRAZ. CRC C2001
340385	PARATIA VENT."POST" CRC C2001
352110	BACK PANEL
352111	BACK PANEL CRC
352112	FRONT COVER CRC
390182	BACK PANEL
390194	BACK PANEL CRC
400826	CRC BATTERY
H26556	HOSE